

# INSTRUCTION

## Instructions for Oral Presentations

1. Every speaker is requested to finish up an arrangement necessary for data project two hours before the respective presentation at the latest, by contacting the staff of the PC Data Registration desk, located in front of the meeting room. It is suggested you to save your final slides in a USB flash memory or CD-R and bring to the PC Data Registration Desk.
2. All speakers are requested to strictly observe the allotted presentation time. Since the conference schedule is tight, session chairpersons will strictly enforce the timing. The staff will press the buzzer for time-reminding.
3. It is required to use the laptop prepared by the conference for stable computer system connection. For any reason that you must use your own laptop, please inform the secretariat in advance.
4. The conference will have a laptop set up at the podium for all presenters. A remote control for changing the slides will be prepared; the presenter can control the slides on his/her own.
5. All presentation slides should be prepared by "Microsoft Office PowerPoint 2003, 2007, or 2010."
6. A single projection will be available. Windows-operated computers will be prepared the organizer. If your slides are prepared by Mac system, the data may deform after its transfer to the Windows system.

Please check and correct this possible deformation at the PC Registration Desk.

7. Video tape presentation is not available. If you need to use video records, please transfer them to the computer in a digital form (Windows Media player). The projection does not support Full HD video mode, please avoid this kind of file format. If you prepare to use a Mac laptop, please bring the Apple DVI to VGA display adapter. The connector of the projector is D-SUB, be sure the correct adapter is brought with you.
8. Please note the time allocated for each presentation as follows:  
20 minutes for presentation followed by 5 minutes of discussion for invited speakers and 10 minutes for presentation followed by 3 minutes of discussion for free paper session and case discussion.

## Instructions for Discussion

1. Active discussions from the floor are encouraged as far as the time is available.
2. All aspects of discussion session shall be ordered by due consideration of chairpersons.
3. Anyone who wishes to raise a question/discussion can raise their hands and wait for an order of chairpersons. To begin your discussion, please identify yourself first.

## Instructions for Poster Presentations

Poster Presentation Operation Hours: Poster set-up time: Feb 18 (Sat) 10:30 - 11:00

Poster removal time: Feb 19 (Sun) 15:30 - 17:00

Location: Poster Session Space, 14th floor, Faculty of Medicine Experimental Research Building, Hongo Campus, University of Tokyo

1. Necessary office supplies for mounting will be provided on-site. Staple guns are prohibited for mounting. Conference will provide free pins for poster presenters.
2. In the event of posters not removed after 17:00 on February 19, the staff will remove them without further notice.
3. All poster board has a surface of 90 cm wide and 180 cm high. Top corner space will be used to place the poster number, pre-fixed by the secretariat.
4. Poster judges will evaluate all posters during Coffee Break & Lunch time. Presenters are suggested to be standby at the site of respective posters for answering questions during those time period.
5. Conference will present awards at the Welcome-party on February 18th. We strongly encourage all free paper presenters to stay on-site to receive the award.

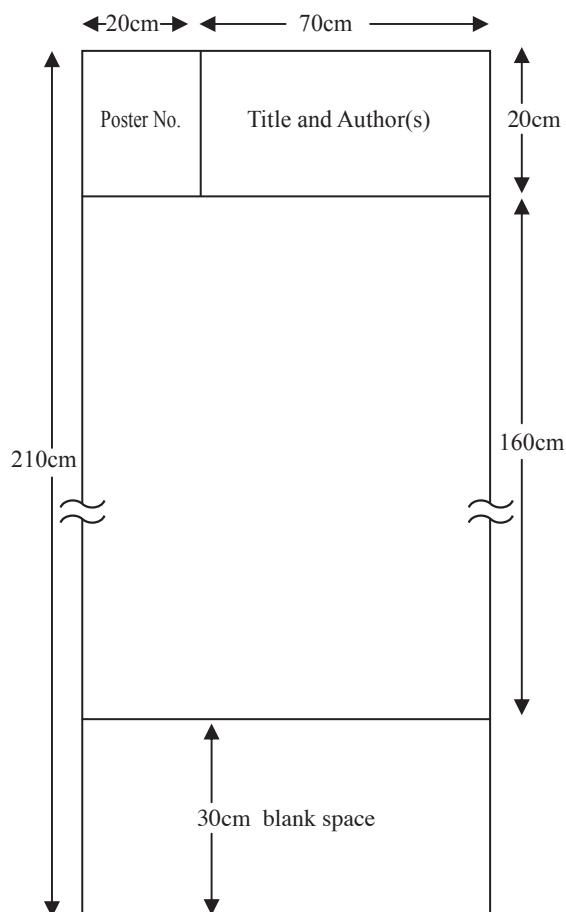

## Awards

\***Japanese Society of Child Neurology Award** (JCSN Award) for 3 presenters

\***ISCE Award** for 4 presenters

\***ISS Nihon Kohden Award** for 6 presenters

Awards will be presented at the welcome-party on February 18th